

The New NBC Filtration and Ventilation System

# Lavi+ System

Compact size with a unique design



## The New Generation of Security for Protected Areas

The Lavi+ system was developed by the RB-Group in conformity with the requirements of the IDF Home Front Command and the Standards Institution of Israel (SII). The system is engineered to provide maximum convenience of operation during times of emergency and a meticulous and unique design for smooth integration of the system in residential reinforced security rooms, giving the protected area the same look and feel as the other rooms in the home.

The system is installed in residential reinforced security rooms, in accordance with Israeli law, in every residential apartment in Israel.

The certified Lavi+ System carries the Israeli Standard Mark SII4570) and IDF Home Front Command certificate according to Regulation 6869.



RB-DOORS

Imaging for illustrative purposes only.

## Choose RB's Lavi+ System

### For RB Security

- The system enables up to 6 people to safely stay in the protected security room without need for wearing NBC gas masks
- The system provides fresh air in ventilation mode, and an optimal level of filtration for filtered air
- The system can be used for a duration of many weeks in states of emergency
- The system can be operated by a single individual
- The 10-year warranty from date of installation brings you peace of mind and personal security  
(Subject to annual maintenance inspection by a certified installer according to the requirements of SII4570)

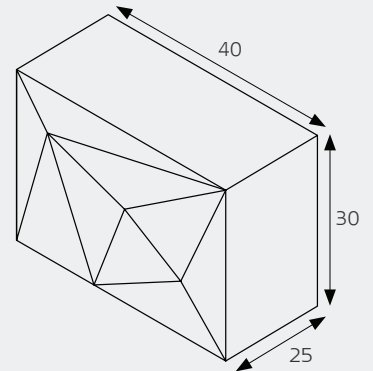

### For RB's Vast Experience

- The RB-Group has over 40 years of experience in the design, development and production of superior security and protection products. The company's long-established reputation is also reflected in the Lavi+ system, which was developed by top Israeli engineers who prioritized excellence and superior quality throughout all stages of development while optimizing suitability to the requirements, regulations and needs of this specific market.

### For Its Design

- The case of the Lavi+ system was designed by Architect Amit Israel in a unique design with a 3D front panel, and boasts the smallest dimensions and volume available today: 25/30/40 cm.

### For Convenient and Flexible Installation and Operation

- There are many ways to install the system in the security room, directly on top of the air intake flange, or anywhere up to a distance range of 1.8 m
- Autonomous switching between ventilation and filtering modes without need for moving a control lever
- Removable accessories compartment for user's convenience
- Intuitive operation- simple and easy
- Simple and quick connection of filter in emergency situations

### For the Technological Innovation

- The Lavi+ filter is a radial air filter type, a world first for home systems
- The small-diameter filter fits into the depth of the wall as needed, even with additional layers caused by different types of wall finishes
- In filter mode, the filter connects without adapters and tubing, for maximum safety against contamination from polluted air
- Uniform air inlet valve suitable for all types of walls and wall finishes, without adapters or adjustments
- Portable electric blower for user's convenience

## System Parts



Filter



Inlet valve and pre-filter



Overpressure relief valve



Electric Blower



Manual Backup Blower



Accessories Compartment

## How the Lavi+ System Works

Installation of system follows testing for airtight seal of the reinforced security room in the final stages prior to receipt of Certificate of Occupancy.

In ventilation mode, the blower intakes air from the outside through a blast valve and injects the air through high pressure compression to the sealed security room.

In filtration mode, all toxins currently known to man are filtered out of the air.

The release valve regulates positive pressure in the security room.

Simple operation instructions are provided on stickers and in an illustrated manual for proper use and maintenance.



All pictures, imaging and sketches are for illustrative purposes only • RB-DOORS reserves the right to improve and/or change the products without prior notice.

© Copyright, 2022 Rav-Bariach (08) Industries Ltd. All rights reserved